



*GE Plastics*  
*Structured Products*

**LEXAN® MR10 Sheet**

**UV- and Abrasion-Resistant  
Vertical Glazing**



**LEXAN® XL10 Sheet**

**UV-Resistant Vertical  
and Overhead Glazing**



**LEXAN® LEXGARD® Laminates**

**Bullet-Resistant and  
Forced-Entry Security Glazing**



**LEXAN® NU-VIEW® Laminate**

**Scratch- and  
Abrasion-Resistant Laminate**



**LEXAN® THERMOCLEAR® Sheet**

**Multi-Wall Translucent  
Thermal Glazing**



Sheet  
Technical Data

# High-Performance LEXAN® Sheet Products To Meet Diverse Glazing Requirements

## Product Selection

Product Characteristics	MONOLITHIC SHEET			PROFILE SHEET	LAMINATED SHEET	
	LEXAN MR10 Sheet	LEXAN 9034 Sheet	LEXAN XL10 Sheet	LEXAN THERMOCLEAR® Sheet	LEXAN LEXGARD Laminates	LEXAN NU-VIEW Laminate
High Impact	X	X	X	X	X	X
Thermoformable		X	X	X		
Cold-Formable		X	X	X		
Forced-Entry Protection	X	X	X	X	X	X
Ballistics Protection					X	
Added UV Resistance	10-Year Warranty*		10-Year Warranty*	10-Year Warranty*	X	10-Year Warranty*
Added Abrasion Resistance	10-Year Warranty*				X	5- Year Warranty*
Privacy Glazing		Prismatic Sheet		Internal Ribbing	Prismatic Laminates	

\* Details of limited warranty available upon request.

## Code Compliance

Code	Listing/Standard Sheet	LEXAN MR10 Sheet	LEXAN 9034 Sheet	LEXAN XL10 Sheet	LEXAN THERMO-CLEAR Sheet	LEXAN LEXGARD Laminates	LEXAN NU-VIEW Laminate
Model Bldg. Codes BOCA 92-15 ICBO 3286 SBCCI 9418 <sup>(1)</sup> Dade County 94-0203.02	Approved plastic material for light-transmitting applications Minimum thickness .080"	X	X	X	X	X	X
Underwriters Laboratories	Burglary-resisting Glazing Standard 972 Minimum thickness .080"	X	X	X	X	X	X
CPSC: 16 CFR 1201, I, II ANSI Z97.1	Meets safety standard for architectural glazing materials categories I & II	X	X	X	X		
Horizontal	CC 1/ASTM D635	X	X	X	X	X*	X***
Burn Rate	CC-2/ASTM D635				X	X**	
UMTA	Urban Mass Transit Admin. flammability and smoke guidelines						X***

<sup>(1)</sup> LEXAN 9365 Corrugated Sheet.

\* LEXGARD MPC-375, MP-1000, MP-500, SP-1250 laminates.

\*\* LEXGARD MP-750 laminate only.

\*\*\* 1/4" LEXAN NU-VIEW laminate.

# Technical Data For LEXAN® Monolithic Sheet

**Table 1: Abrasion Resistance Comparison (LEXAN MR10 Sheet)**

	Test Method	Uncoated Polycarbonate (Δ % Haze)	LEXAN MR10 Sheet/ LEXGARD Laminates (Δ % Haze)	Glass (Δ % Haze)
Taber Abrasion 100 Cycles	ASTM D1044 Z26.1	35.0	3.0 - 4.5	0.5
Falling Silica Carbide 1600 grams	Z26.1	30.0	5.0 - 8.0	15.0 - 20.0
GE Brush Abrasion Tester	One hour harsh conditions*	30.0	3.0	1.0

\* Abrasive water mixture of sandy clay screened through 100 mesh screen and continuously applied to brush water.

**Table 1a: NU-VIEW® Laminate**

Condition	Test Method	Typical Value Laminated to LEXAN MR10 Sheet/ NU-VIEW Laminate (Δ % Haze)
Taber Abrasion 100 Cycles	CS-10F wheel, 500 grams ASTM D1044	3.0 - 4.5

\* Abrasive water mixture of sandy clay screened through 100 mesh screen and continuously applied to brush water.

**Table 2: U-Value Comparison**

Summer Heat Gain (BTU/hr.-sq.-°F)			
Thickness	LEXAN Sheet	Glass	% Advantage Over Glass
.080"	1.00	1.04	4
.093"	1.00	1.04	4
.118"	.97	1.04	7
.177"	.93	1.04	11
.236"	.90	1.04	14
.375"	.83	1.03	19
.500"	.77	1.03	25
Dual Glazed*	.45	.56	20
Winter Heat Loss (BTU/hr.-sq.-°F)			
Thickness	LEXAN Sheet	Glass	% Advantage Over Glass
.080"	1.10	1.16	5
.093"	1.08	1.16	7
.118"	1.05	1.16	10
.177"	1.01	1.15	12
.236"	.96	1.14	16
.375"	.88	1.11	21
.500"	.82	1.09	25
Dual Glazed*	.43	.49	12

\* Two 1/4" lites with 1/2" air space.

**Table 3: Sound Transmission**

Thickness	STC Rating	
	LEXAN Sheet	Float Glass
.118"	25	23
.177"	29	-
.236"	31	27
.375"	34	-
.500"	34	32
1.0"	39	-
1.25"	42	-

**Table 4: Light and Energy Transmittance\***

Thickness	Clear 112 % Values		Grey 713/Bronze 5109 % Values		Green 31035 % Values		Greylite 7135 % Values	
	Visible Light	Solar Energy	Visible Light	Solar Energy	Visible Light	Solar Energy	Visible Light	Solar Energy
.118"	86	89	50	60	79	82	14	22
.177"	85	88	50	60	78	81	18	28
.236"	83	86	50	60	72	78	17	26
.375"	79	84	50	60	77	80	16	24
.500"	75	81	50	60	75	79	26	36

\* Uniform transmittance is a quality of both bronze and grey tints of transparent LEXAN sheet through all thicknesses. Other light transmittance requirements can be custom manufactured as desired.

**Table 5: Weight**

Thickness	LEXAN Sheet (lbs./ft.²)	Glass (lbs./ft.²)
.080"	.50	1.02
.093"	.58	1.20
.118"	.73	1.60
.177"	1.10	2.40
.236"	1.46	3.20
.375"	2.34	4.80
.500"	3.12	6.40

**Table 6: Cold-Bending Radii**

Sheet Thickness (in.)	Recommended Minimum Radius (in.)
.118"	11.8"
.177"	17.7"
.236"	23.6"
.375"	37.5"
.500"	50.0"

**Table 7: Shading Coefficient**

1/4" Thickness	
LEXAN Single Glazed – Clear	1.02
LEXAN Single Glazed – Light Green	.92
LEXAN Single Glazed – Grey/Bronze	.79
LEXAN Single Glazed – Greylite	.48
LEXAN Dual Glazed* – Clear/Bronze	.67
Tempered Glass Dual Glazed – Clear	.90

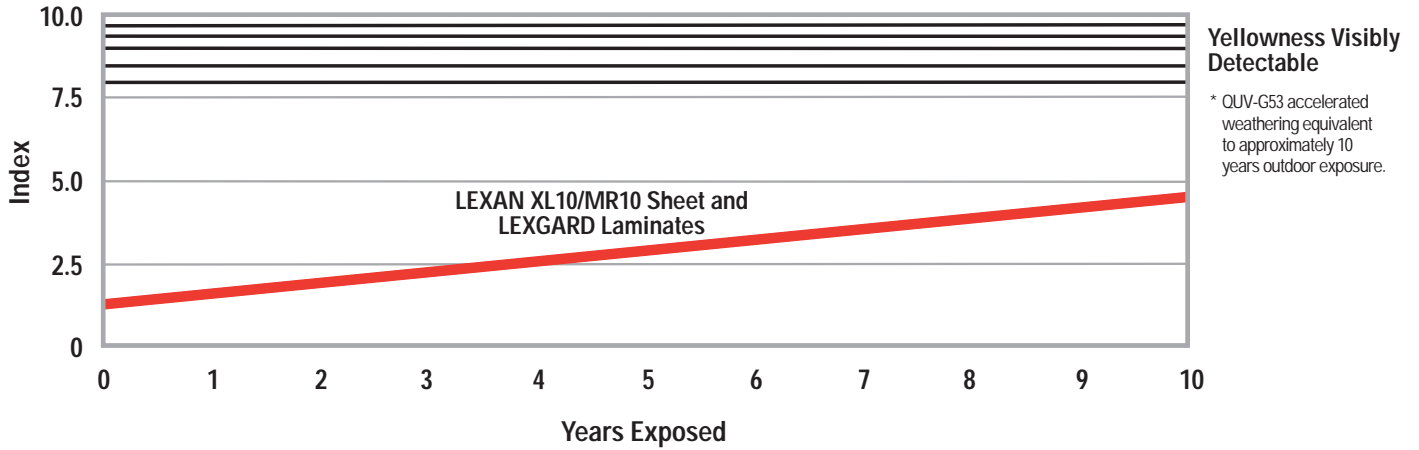
\* Tinted LEXAN sheet, exterior lite, 1/4" air space, clear LEXAN sheet interior lite.

**Table 8: Coefficients of Thermal Expansion**

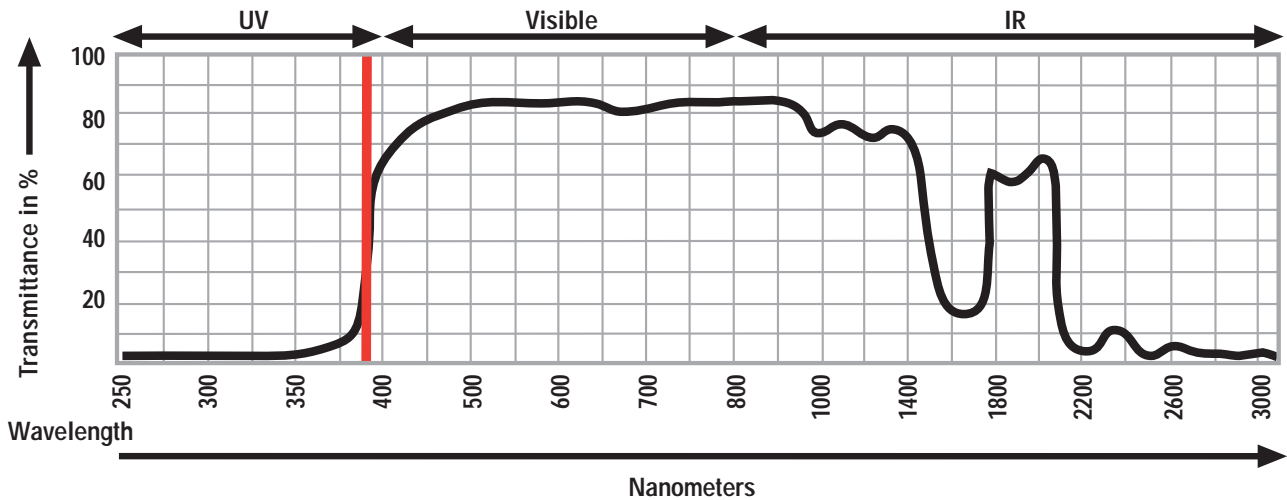
Building Material	Inches/Inch/°F
Glass	.0000050
Aluminum	.0000129
LEXAN Sheet	.0000375
Acrylic	.0000410
Steel	.0000063
Copper	.0000090

# Technical Data For LEXAN® Monolithic Sheet (Continued)

**Figure 1: Yellowness Index\***  
(LEXAN XL10/MR10 Sheet and LEXGARD® Laminates)



**Figure 2: Ultraviolet Light Transmission\***



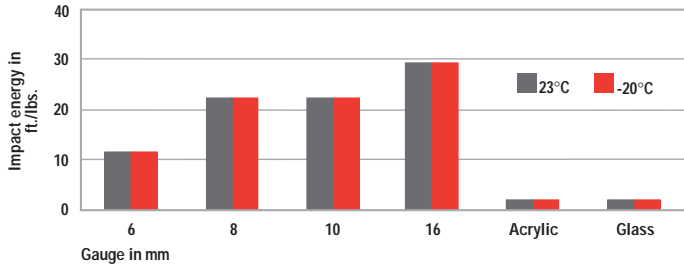
\* All grades of LEXAN sheet are essentially opaque at all wavelengths below 385 nanometers, making LEXAN sheet excellent for protecting art objects, display merchandise and fabrics from damaging effects of UV light.

# Technical Data For LEXAN® THERMOCLEAR® Sheet

**Table 9: Calculated U-Value Comparison**

Heat Gain (BTU/hr.-sq. ft.-°F)			
Thickness	LEXAN THERMOCLEAR Sheet	Single Layer Glass	% Advantage Over Glass
6mm (.236")	.61	1.04	40
8mm (.315")	.58	1.04	43
10mm (.395")	.52	1.03	45
16mm (.629")	.42	1.07	49

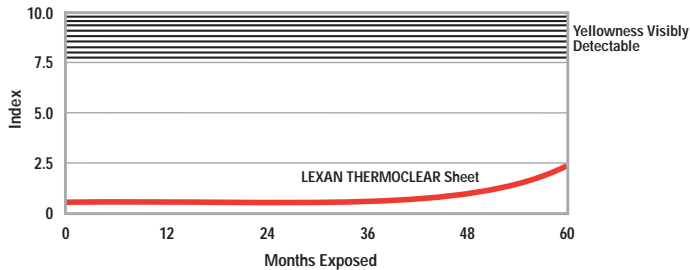
**Table 10: Impact Resistance  
(Gardner Falling Dart Impact Test)**



**Table 11: Weight**

Thickness	LEXAN THERMOCLEAR Sheet (lbs./ft. <sup>2</sup> )	Glass (lbs./ft. <sup>2</sup> )
6mm (.236")	.27	3.02
8mm (.315")	.35	4.03
10mm (.395")	.41	5.03
16mm (.629")	.57	8.05

**Figure 3: Yellowness Index**



**Table 12: Calculated Shading Coefficients**

Thickness/Color	Single Glazed	Dual Glazed	
6mm	Clear	.98	.85
	Light Bronze	.70	.49
	Dark Bronze	.61	.40
	Opal	.66	.47
	White	.53	.32
8mm	Clear	.96	.82
	Light Bronze	.70	.49
	Dark Bronze	.61	.40
	Opal	.66	.47
	White	.53	.32
10mm	Clear	.89	.72
	Light Bronze	.70	.49
	Dark Bronze	.61	.40
	Opal	.66	.47
	White	.53	.32
16mm	Clear	.87	.69
	Light Bronze	.70	.49
	Dark Bronze	.61	.40
	Opal	.66	.47
	White	.53	.32

**Table 13: Light and Energy Transmittance\***

Thickness	Clear % Values	
	Visible Light	Solar Energy
6mm (.236")	82	86
8mm (.315")	82	86
10mm (.395")	80	85
16mm (.629")	74	82

\* Uniform transmittance is a quality of both bronze and white tints of transparent LEXAN sheet through all thicknesses. Other light transmittance requirements can be custom manufactured as desired.

**Table 14: Cold Forming**

Gauge	Radius (inches)
6mm	41"
8mm	55"
10mm	69"
16mm	110"

# Technical Data For LEXAN® LEXGARD® Laminates

**Table 15: Product Descriptions**

LEXAN LEXGARD Laminates	Actual Gauge (inches)	Weight (lbs./sq. ft.)	Shading Coefficient (calculated)	U-Factor	Test Ratings
MP-750 (3-ply)	.775 ± 8%	5.1	1.04	.68	ASTM F1233 (.38 Super) UL 752 MPSA HPW Level B-I
MP-1000 (4-ply)	1.050 ± 5%	6.5	.93	.60	ASTM F1233 (.38 Super) Class V Step 40 UL 752 MPSA HPW Level B-III
SP-1250 (4-ply)	1.330 ± 5%	8.1	.90	.54	ASTM F1233 (.44 mag) Class V Step 41 UL 752 SPSA HPW Level C-III
PL-250 (2-ply)	.265 ± 5%	1.6	1.00 prism in .90 prism out	.96	ASTM F1233 Class II Step 5 UL 972 HPW Level I
PL-375 (2-ply)	.390 ± 5%	2.4	.99 prism in .86 prism out	.86	ASTM F1233 Class III Step 8 HPW Level II (Step 10)
PL-500 (3-ply)	.530 ± 5%	3.2	.99 prism in .86 prism out	.82	ASTM F1233 Class III Step 10 HPW Level A-II (Step 14)

**LEXAN LEXGARD Laminates for Component Systems**

**NOTE:** These materials have no ballistic ratings in and of themselves but are to be used as components in systems including laminated safety glass and appropriate air spaces to achieve specific ballistic ratings. These systems are available from authorized LEXGARD laminates fabricators.

**Standard Colors:** Clear, Bronze and Gray. LEXGARD PL-375 laminates are available in Clear only. Custom colors quoted on request.

**Six Standard Sizes:** Maximum for all grades, 60" x 96".

LEXGARD Component Laminates	Actual Gauge (inches)	Weight (lbs./sq. ft.)	Shading Coefficient (calculated)	U-Factor	Test Ratings*
MPC-375 (2-ply)	.390 ± 5%	2.4 (with 1/4" glass, 5.6)	1.03 (with 1/4" glass, .96)	.86 (with 1/4" glass, .47)	ASTM F1233 Class III Step 9 HPW Level A-II (Step 10) Systems are available to meet UL 752 MPSA
MPC-500 (3-ply)	.530 ± 5%	3.3	1.01	.80	ASTM F1233 Class III Step 15 HPW Level A-II (Step 14)
RC-750 (3-ply)	.780 ± 5%	4.9 (with 3/4" glass, 15.1)	.96 (with 3/4" glass, .86)	.68 (with 3/4" glass, .40)	ASTM F1233 Class IV Step 21 HPW Level B-II Systems are available to meet UL 752 HPR
GC-938 (4-ply)	.980 ± 5%	6.1 (with 3/4" glass, 16.3)	1.00 (with 3/4" glass, .95)	.62 (with 3/4" glass, .35)	UL 752 Class IV 30.06 rifle protection and 7.62 NATO protection when used behind 3/4" (1/8", 1/2", 1/8") laminated safety glass

\* All ASTM test results listed are Body Passage Test results. Contraband Passage Results available upon request.

# Glazing And Installation Guidelines For High-Performance LEXAN® Sheet

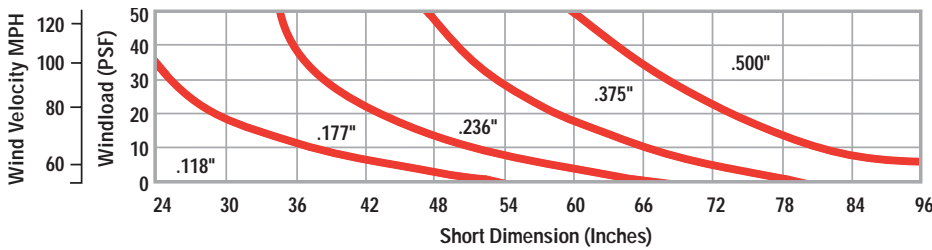
All grades of LEXAN sheet can be glazed easily when proper procedures are followed. When designing with LEXAN sheet, remember to allow for its thermal expansion and greater flexibility in accordance with these guidelines.

The tables and accompanying directions provide information necessary for proper installation.

## Glazing Recommendation Thickness

Recommended guidelines for selecting thickness based on the short dimension are shown in the Windload Chart (Figure 4). Table 16 gives required edge engagement and expansion allowance, depending on sheet thickness.

**Figure 4: Windload Chart**



**Table 16: Sheet Thickness, Edge Engagement\*, Expansion Allowance\*\* and Rabbet Depth\*\*\* (Based on ±50°F temperature shift from installation)**




Glazing Dimensions	Up to 24"	25"-36"	37"-48"	49"-60"	61"-72"	73"-96"	97"-120"
LEXAN Sheet Thickness (use short dimension)	.118"	.177"	.236"	.375"	.500"	.500"	.500"
Edge Engagement (use long dimension)	5/16"	1/2"	5/8"	3/4"	7/8"	1"	1 1/4"
Expansion	1/32"	1/16"	3/32"	3/32"	1/8"	5/32"	3/16"
Contraction	1/32"	1/16"	3/32"	3/32"	1/8"	5/32"	3/16"
Total Rabbet Depth	3/8"	5/8"	13/16"	15/16"	1 1/8"	1 5/16"	1 5/8"

\* Based on 40 PSF design load.

\*\* Trim the sheet by the amount indicated in the expansion column.

\*\*\* Expansion + contraction + edge engagement = Total Rabbet Depth.

**Table 17: Calculating Rabbet Depth**

.0000375 x Temperature Span x Length	Expansion & Contraction
Example	
48" x 96" Sheet	
Expansion = .0000375 x 50° x 96" = .18"	110°F Expansion 
Contraction = .0000375 x 50° x 96" = .18"	60°F Installation Temperature 
Edge Engagement Based on 40psf = 1"	10°F Contraction 
Total Rabbet Depth = 1.36"	

These recommendations consider deflection, windload and normally available rabbet and channel depths. Horizontal or sloped applications may require thicker sheets, smaller spans, additional support consideration or increased rigidity by forming. Aesthetic requirements regarding deflection should be taken into consideration by the architect, the building owner and the client.

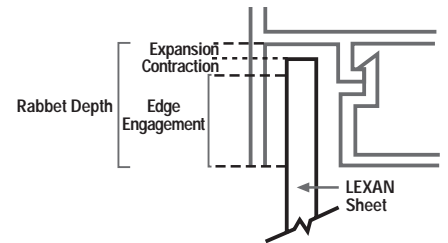
## Rabbet Depth

Recommended rabbet depth guidelines are given in Tables 16 and 17. Specific edge engagement and expansion allowance recommendations consider the thermal and structural properties of LEXAN sheet.

## Computer-Aided Sheet Engineering (CASE)

The computer-aided design program is a structural analysis system, developed specifically for more complex LEXAN sheet (sloped or curved) glazing applications. The CASE program incorporates large deflection capabilities (nonlinear) and takes into account the added in-plane stiffening of the glazing panel caused by the sheet stretching as it deflects. The bottom line: CASE recommends the optimum performance of the LEXAN glazing material and allows you to design with confidence.

**Figure 5: Rabbet Depth Detail**



Rabbet Depth = Expansion + Contraction + Edge Engagement

## Temperature-Humidity Bowing

Certain temperature and humidity conditions, either interior or exterior, can cause a slight bowing of the LEXAN sheet, usually in the direction of the higher temperature or humidity. This bowing is reversible and flatness can be restored to the sheet by equalization of the factors that cause bowing.

Although bowing does not affect visibility, it can cause distorted reflections. Specifying thicker grades of LEXAN sheet and increasing the sash edge engagement are ways of reducing distortion and bowing.

Special consideration should be given in the sash design for slide-by windows to accommodate LEXAN sheet bowing. GE Plastics Structured Products recommends that all sliding sash systems be environmentally tested to ensure adequate clearance.

# Glazing And Installation Guidelines For High-Performance LEXAN® Sheet (Continued)

## How to Cut LEXAN Sheet

LEXAN sheet can be cut easily and accurately to the exact size desired with most power saws. Protective masking should be left in place to prevent marring.

Glazing details pictured in this publication represent typical examples only. For specific application information, contact GE Plastics Structured Products.

**Caution:** Circular saw blades must be of triple-chip design. Failure to use this type of blade can result in uncontrollable chattering, and injury from flying pieces of glazing may result. When hand tools are used, the sheet should be clamped to the work table to avoid undesirable vibration. Strict safety precautions should be observed during the cutting of LEXAN sheet. Remember take care to protect yourself from injury. Use appropriate eye and ear protection and exercise caution when operating equipment.

## Glazing Precautions

Glazing of LEXAN sheet should be considered a finishing operation and should be scheduled as a final step in completion of a building.

- Care should be taken to avoid surface marring during storage, cutting, transportation and installation.
- After installation and removal of masking, LEXAN sheet should be protected from paint, plaster and other splashes by polyethylene, or other covering, taped to framing members.

## Glazing of Small Lites (up to 24" x 24")

LEXAN sheet can be glazed in a wood or metal sash. Figure 10 demonstrates typical details. Refer to Figures 4 and 10 and Tables 16 and 17 to establish proper edge engagement, expansion allowance and rabbet depth.

Non-hardening glazing compounds, including acrylic latex caulks, can be used, although high grade sealants such as silicone are most highly recommended.

## Glazing of Intermediate and Large Lites (over 24" x 24")

### Wet-Glazing Systems

Figure 8 on page 10 shows a typical channel-glazed system that has been successfully designed to accommodate LEXAN sheet. Refer to Figure 5 and Tables 16 and 17 to establish proper edge engagement, thermal expansion allowance and rabbet depth. Only high-grade silicone sealants and fully-cured butyl tapes are recommended.

### Dry-Glazing Systems

Dry glazing should be considered in applications where sheet expansion may exceed sealant limitations and result in failure (i.e., sloped, curved skylights). In such cases, EPDM, silicone or neoprene gasket manufacturers such as Tremco Manufacturing Company or Norton Company should be contacted about the correct use of their products.

**PVC gaskets typically are not compatible with polycarbonate** and are not recommended for use in contact with LEXAN sheet. Figure 12 on page 11 shows typical dry-glazing design.

### Dual Glazing

LEXAN sheet products, including LEXGARD laminate components, can be used effectively in dual-glazed window systems, in double-channeled sash units or for overglazing and backglazing (Figure 11). When using LEXAN sheet in a dual-glazed application, remember to allow for its greater flexibility and expansion. Providing adequate separation between the two LEXAN glazing panels will prevent the LEXAN sheets from touching during certain temperature and humidity conditions.

Glazing of intermediate and large lites may require the application of small spacers between the LEXAN sheet panels to maintain the dead air space. LEXAN sheet is a permeable glazing material and should not be used in a sealed, insulated unit. However, dual-glazed systems, when properly vented, are acceptable. Contact GE Plastics Structured Products for more information and names of sash manufacturers that have approved systems.

Table 18 lists sealants, gaskets and tapes recommended for use with LEXAN sheet. Manufacturers should be contacted concerning the specifications and correct use of their products. The products listed in Table 18 are examples only, and are not intended to exclude use of products made by other manufacturers.

### Cold-Bending LEXAN Sheet

LEXAN sheet products (except LEXAN MR10 sheet and LEXGARD laminates) can be bent while cold to simple curvatures and held to the radius by springing the material into a curved framing or retention system. The recommended minimum radius of curvature is 100 times the thickness, as shown in Table 6.

### Chemical Compatibility

System compatibility is essential to ensure long-term performance of LEXAN glazing materials.

Whether during fabrication or in end-use application, any material coming in contact with LEXAN sheet should be compatible at the actual temperature and loading anticipated.

For compatibility testing of materials not listed here, call GE Plastics Structured Products at 1-800-451-3147.

### Installation Procedures

1. Prepare sash. Clean sash surface and prime if necessary. Rabbet should be free of burrs.
2. Prepare LEXAN sheet. After measuring sash opening carefully, determine recommended edge engagement and expansion allowance. Cut sheet to exact size required. Edges should be clean and free of notches.
3. Glaze LEXAN sheet. Sealants and tapes with sufficient extensibility to accommodate thermal expansion and contraction without loss of adhesion to either frame or sheet must be used.

# Glazing And Installation Guidelines/Cleaning Instructions

## Recommended Sealants, Gaskets and Tapes for Window Systems

For information on recommended window systems, contact your preferred window manufacturer or your local LEXAN® sheet sales office.

**Table 18: Recommended Sealants, Gaskets and Tapes**

Type	Manufacturer	Product Name
Silicone	General Electric Company Waterford, NY (800) 255 8886	Ultrapruf Sealant
Silicone	General Electric Company Waterford, NY (800) 255 8886	Silpruf® Sealant
Silicone	General Electric Company Waterford, NY (800) 255-8886	CONSTRUCTION 1200® Sealant
Silicone	General Electric Company Waterford, NY (800) 255-8886	CONTRACTORS 1000® Sealant
Gasket / Tape	Norton Company Granville, NY (800) 724-0883	• NORRENE* Foam • V-2100 Urethane Series
Gasket	Tremco Columbus, OH (800) 321-6357	• Silicone (70 Durometer) • EPDM (60, 70 Durometer)
Tape	Tremco Cleveland, OH (800) 321-7906	440 Tape
Butyl Tape	PTI Dayton, OH (800) 543-7570	303, 606
Butyl Tape	Schnee-Morehead Irving, TX (214) 438-9111	Isocryl 5600 Series
Aluminum/ Mesh Tape	DRG Sellotape Utrecht, Holland 030-44 33 44	Sellotape BV Vent Tape
Vent Tape	3M Minneapolis, MN (612) 733-1110	Tape 394

\* Registered trademark of Norton Company.

## Installing LEXAN THERMOCLEAR® Sheet

When installing LEXAN THERMOCLEAR sheet, it is important to allow for thermal expansion to minimize bowing. Sheets should be mounted with the ribs running vertically and the bottom edge sealed with permeable tape to assist condensed water vapor drainage.

## Cleaning Instructions

When LEXAN sheet is first installed, glazing compound and masking paper adhesive can be easily removed by applying naphtha (VM&P) or kerosene with a soft cloth, followed immediately with a thorough soap and water cleaning. DO NOT USE GASOLINE. Adherence to regular and proper cleaning procedures is recommended to preserve appearance.

### Washing to Minimize Scratching

Wash LEXAN XL sheet and LEXAN THERMOCLEAR sheet with a mild soap or detergent (e.g., Joy<sup>1</sup> Dishwashing Liquid) and lukewarm water using a clean sponge or a soft cloth. Rinse well with clean water. Dry thoroughly with a chamois or moist cellulose sponge to prevent water spots. Do not scrub or use brushes on these products: their coating is UV-resistant, not mar-resistant.

Fresh paint splashes, grease and smeared glazing compounds can be removed easily before drying by rubbing lightly with a grade of VM&P naphtha or isopropyl. Afterward, a warm final wash should be made, using a mild soap or detergent solution and ending with a thorough rinsing with clean water.

### Minimizing Hairline Scratches

Scratches and minor abrasions can be minimized by using a mild automobile polish. Four such products that tend to polish and fill scratches are Johnson Paste Wax, Novus Plastic Polish #1 and #2 (Novus Inc., Minneapolis, MN), Mirror Glaze plastic polish (M.G.M10 – Mirror Bright Polish Co., Pasadena, CA), and Plexus<sup>1</sup> (B.T.I. Chemical, Aguora, CA). It is suggested that a test be made on a sample of LEXAN sheet with the product selected and that the polish manufacturer's instructions be followed.

### Some Important "Don'ts"

- DO NOT use abrasive or highly alkaline cleaners on LEXAN sheet products.
- Never scrape LEXAN sheet products with squeegees, razor blades or other sharp instruments.
- Benzene, gasoline, acetone or carbon tetrachloride should never be used on LEXAN sheet products.

## Proper Drainage

Purlin should run parallel to the width (perpendicular to the ribs) of each sheet. Values are calculated for 48" and 72" wide sheet with proper edge engagement, expansion allowance and recommended glazing practices. Dry Glazing systems are similar to monolithic sheet. See guidelines on page 8.

- DO NOT clean LEXAN sheet products in hot sun or at elevated temperatures.
- DO NOT use butyl cellosolve on XL10 or TC-2.

## Compatible Cleaners for LEXAN Sheet Products

The following cleaning agents have been found compatible with LEXAN sheet, LEXAN XL sheet and LEXAN THERMOCLEAR sheet. The manufacturer's recommendations and instructions should be followed.

- Joy<sup>2</sup>
- Freon T.F.
- Palmolive Liquid<sup>3</sup>
- Top Job<sup>2</sup>
- VM&P grade naphtha
- Windex with Ammonia D<sup>4</sup>

## LEXAN MR10 Sheet Cleaning Instructions

Because of this material's highly mar- and UV-resistant coating, avoid the use of abrasive cleaners and/or cleaning implements that may mar or gouge the coating.

### Graffiti Removal for LEXAN MR10 Sheet

- Butyl cellosolve works well for removal of paints, marking pen inks, lipstick, etc.
- Masking tape, adhesive tape or lint removal tools work well for lifting off old, weathered paints.
- To remove labels stickers, etc. the use of kerosene or VM&P naphtha is generally effective. When the solvent will not penetrate sticker material apply heat (hair dryer) to soften the adhesive and promote removal. GASOLINE SHOULD NOT BE USED.

### Job Site Precautions

New construction and renovations frequently require that the glazing and surrounding sash and wall finish be cleaned of any excess mortar, paint, sealant, primers or other construction compounds. **Only** recommended cleaners should be used to clean LEXAN sheet. Contact with harsh solvents such as methyl ethyl ketone (MEK) or muriatic acid can result in surface degradation and possible crazing of LEXAN sheet.

<sup>1</sup> Registered trademark of B.T.I. Chemical.

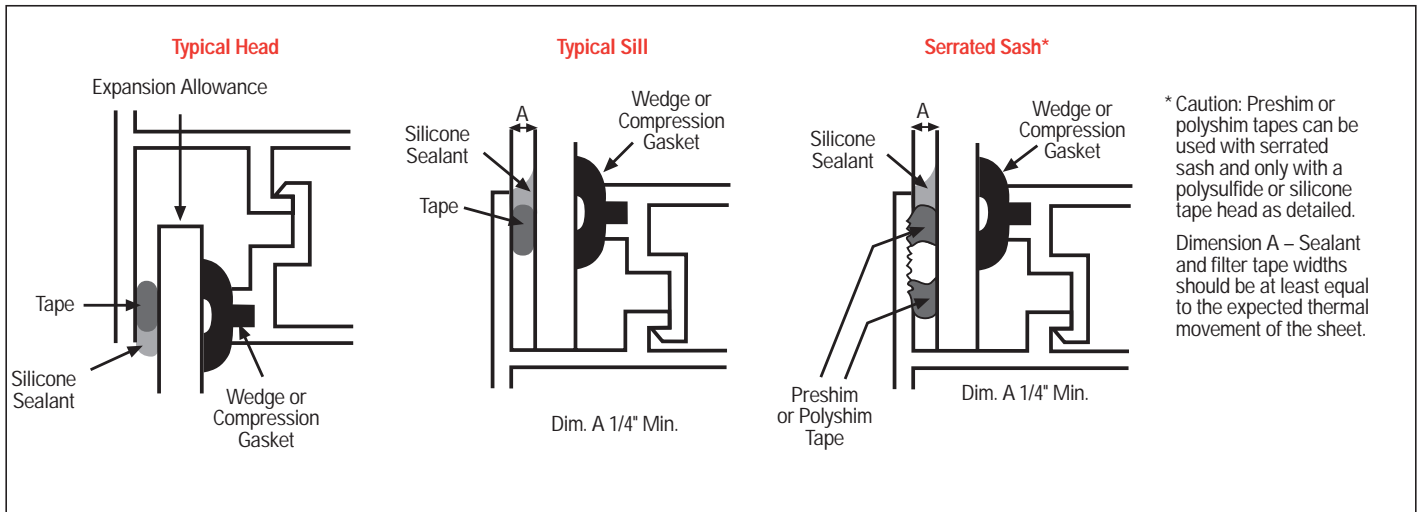
<sup>2</sup> Registered trademark of Proctor and Gamble.

<sup>3</sup> Registered trademark of Colgate Palmolive.

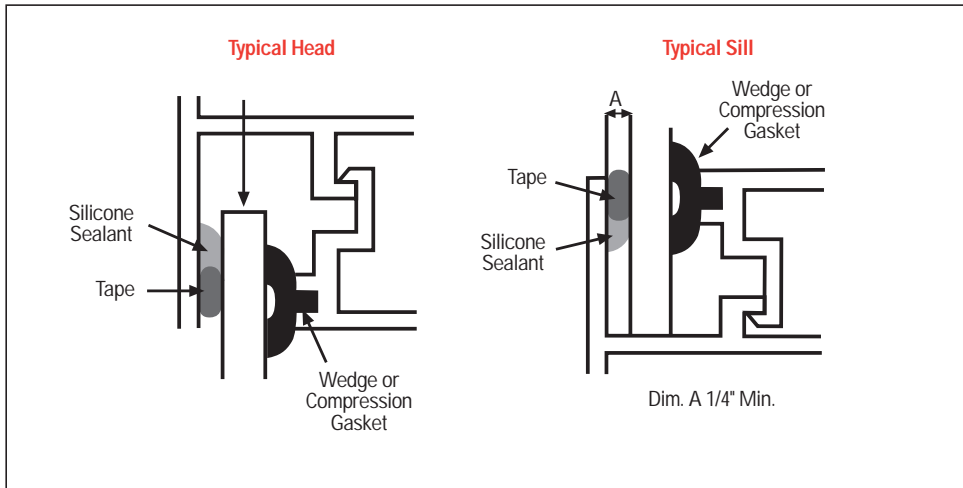
<sup>4</sup> Registered trademark of the Drackett Products Company.

# Glazing And Installation Guidelines/Cleaning Instructions (Continued)

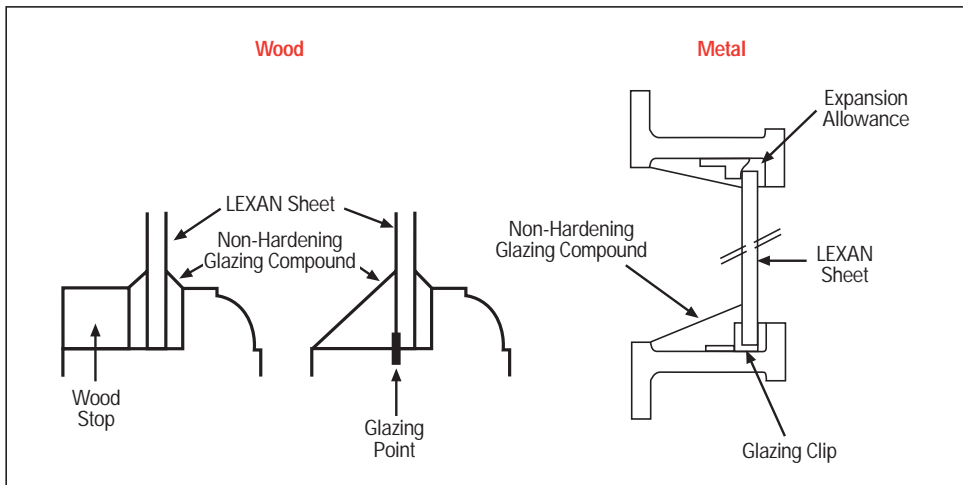
**Figure 8: Wet Glazing Details**



**Figure 9: Interior Glazing Details**

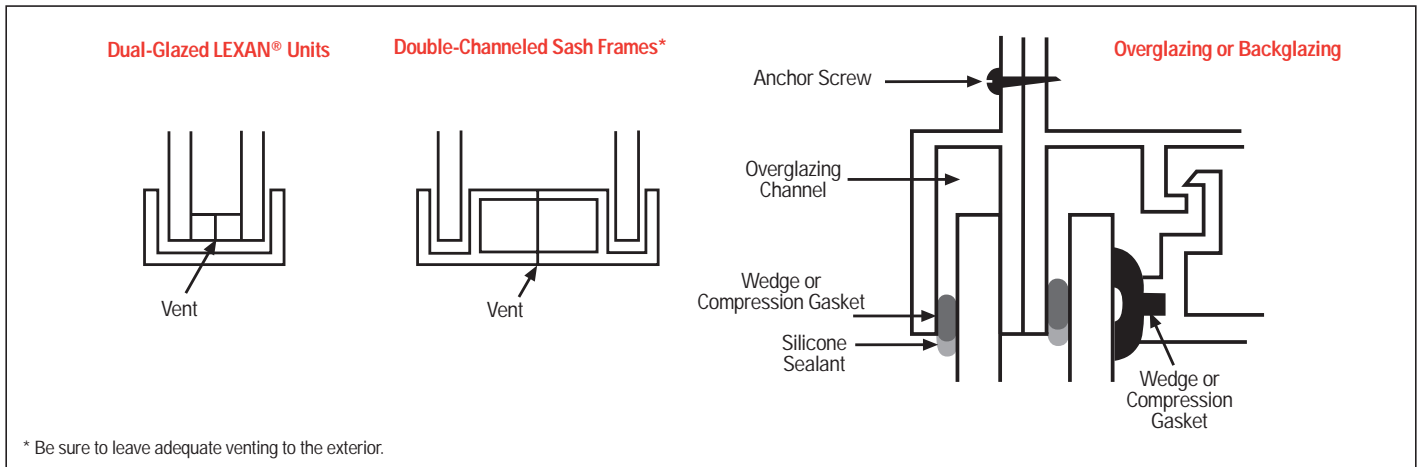


**Figure 10: Typical Sash Details**

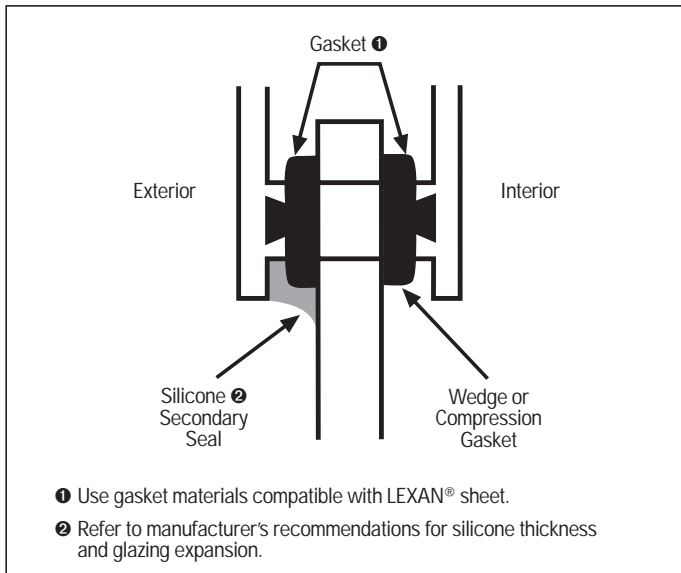


# Glazing And Installation Guidelines/Cleaning Instructions (Continued)

**Figure 11: Dual-Glazed Window Details**



**Figure 12: Dry Glazing Details**



**Figure 13: Channel/Weeping Detail (LEXAN THERMOCLEAR® Sheet)**

